

120 SERIES



FEATURES & BENEFITS

"ACCUWAY" Spread Pattern Equalizer
ENSURES spreading dead center of the
spreader. (Indicated with "22" in model number)



20 SERIES

Gears are unconditionally guaranteed
ENSURES trouble free operation.

MODEL 179



Dial-A-Matic spread rate control
ENSURES spreading at exact spread
rates.

Optional **BORDER PATROL** spread pattern
cut-off prevents spreading on drive-ways,
flower beds, etc.

MODEL 88



Extension hoppers available for all round
hopper spreaders. Adds 20 lbs. to
capacity.

Shipped Set-Up. Saves time and labor
ENSURES proper assembly. (except #64)

MODEL 298
Mulch Spreader

Stainless steel frames ensure longer
spreader life, easier maintenance and
present a quality image.

MODEL 299
Mulch Spreader



High grade plastic non-corroding wheels
with nylon bearings, no lubrication
required, **ENSURES** trouble free
maintenance.

P.O. Box 7 • Urbana, IN 46990 USA
1-800-972-6130 • Fax 260-774-3416

SPYKER

THE SPREADER PEOPLE

spread with confidence

Spreading Chart

Operation Guide

Service Manual

Parts List

For Models:
76-22 | 96-22
78-22 | 98-22



Model:
98-22
pictured

It's the spread that counts

P.O. Box 7
140 Mill Street
Urbana, IN
46990 USA



1-800-972-6130
Fax: 260-774-3416

**For Quick and Easy Assembly - First Read Entire Procedure
Then Follow Carefully The Step by Step Instructions**

Tools you will need:

Medium Sized Screwdriver
7/16" & 3/8" wrenches
Hammer
Pliers

Parts you will use:

Parts for Models:

76-22|96-22
78-22|98-22

- (3) 1/4 - 20 x 1 1/2" 55 bolt
- (8) 1/4 - 20 55 hex nut
- (3) 1/4 - 20 x 1 3/4" 55 bolt
- (1) 1/4 - 20 x 2 3/4" 55 bolt
- (1) 1/4 - 20 x 1" bolt
- (2) 10 - 24 x 1 1/2" 55 bolt
- (2) 10 - 24 55 lock nut
- (2) handle grips
- (1) agitator wire
- (4) handle/tow bar braces
- (1) cable clamp
- (1) felt washer
- (1) manual
- (1) 1/4 - 20 x 1" 55 bolt

1.

Sit spreader assembly on hopper as shown.



2.

For **stainless steel models** remove nuts and bolts that attach front of hopper to frame as indicated, and then insert Bump Bar (3) into frame assembly. Next, re-insert bolts and tighten nuts.



Note: For **black frames** remove nuts and bolts that attach front hopper to frame. Push bump bar into frame (Black bump bars do not have holes drilled in them). Re-insert bolts and nuts and tighten against the bump bar.

3.

Attach braces (8) to frame with bolts (37) and nuts (34). Attach braces to towbar, and towbar to frame using 2 bolts (35) and nuts (34).

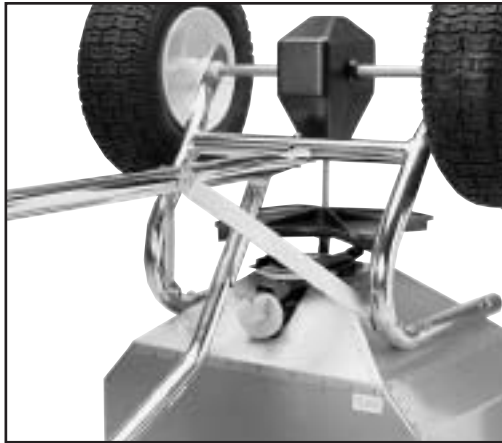

4.

Attach Hitch plates (44) to Tow Bar assembly using 2 bolts (35) and nuts (34).

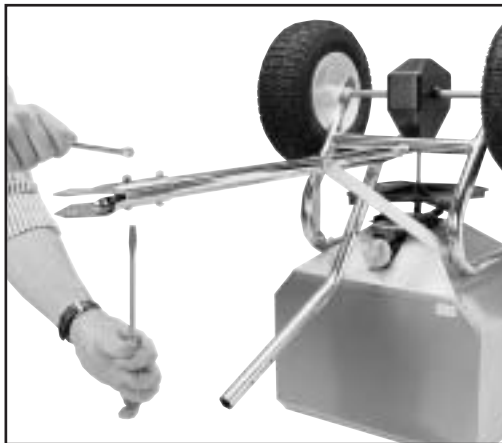

5.

Insert Clevis Pin (43) into Hitch Plates and fasten with Cotter Pin (42).



6.

Attach On/Off Lever Control (46) to Tow Bar assembly using 2 bolts (32) and nuts (33).



Proceed to page 9 for instructions on connecting cable to Rate Gate Linkage.

Walk Behind Frame Assembly

1.

Remove nuts and bolts that attach front of hopper to frame as indicated and then insert Bump Bar (3) into frame assembly. Next, re-insert bolts and tighten nuts.



2.

Insert T-Handle (6) into Ground Prop (5) and fasten with 2 bolts (37) and nuts (34).



Walk Behind Frame Assembly

3.

Attach T-Handle assembly to frame with 1 bolt (31) and nut (34).



4.

Attach Braces (8) to frame and T-Handle assembly. Use 3 bolts (35) and nuts (34) to attach braces to the frame and to the round tube of ground prop. Use bolt (57) and nut (34) to attach braces to the flat support section of ground prop.



5.

Attach On/Off Control Lever (13) to T-Handle assembly using 2 bolts (32) and nuts (33).



New Linkage Adjustment Procedure

1. Set regulator dial to 1.
2. Set lever completely to off position.
3. Attach cable clamp (59) to ground prop with 1 1/4" bolt and nut and finger tighten.
4. Route cable through clamp, then through swivel and then tighten the cable clamp bolt just enough to allow the cable to slide back and forth easily.
5. Adjust sheath on cable so there is a 1/8" inch of control wire that is visible between the sheath and the edge of the rate gate linkage.
6. Tighten the cable clamp bolt to secure the sheath.
7. Tighten the screw on the cable fastener to anchor the wire, making sure that the rate gate linkage is pushed up against the dial.
8. Trim excess wire behind cable fastener connector when finished (if necessary).



Dial Setting Information

The RATE DIAL has 9 numbers with 10 stops between each number, for accurate control of the spreading rate.

The dial is set with only a turn. It will automatically lock into the set position. LINE UP THE DIAL NUMBER WITH THE DIAL INDICATOR.



Exploded View

Walk Behind Hopper

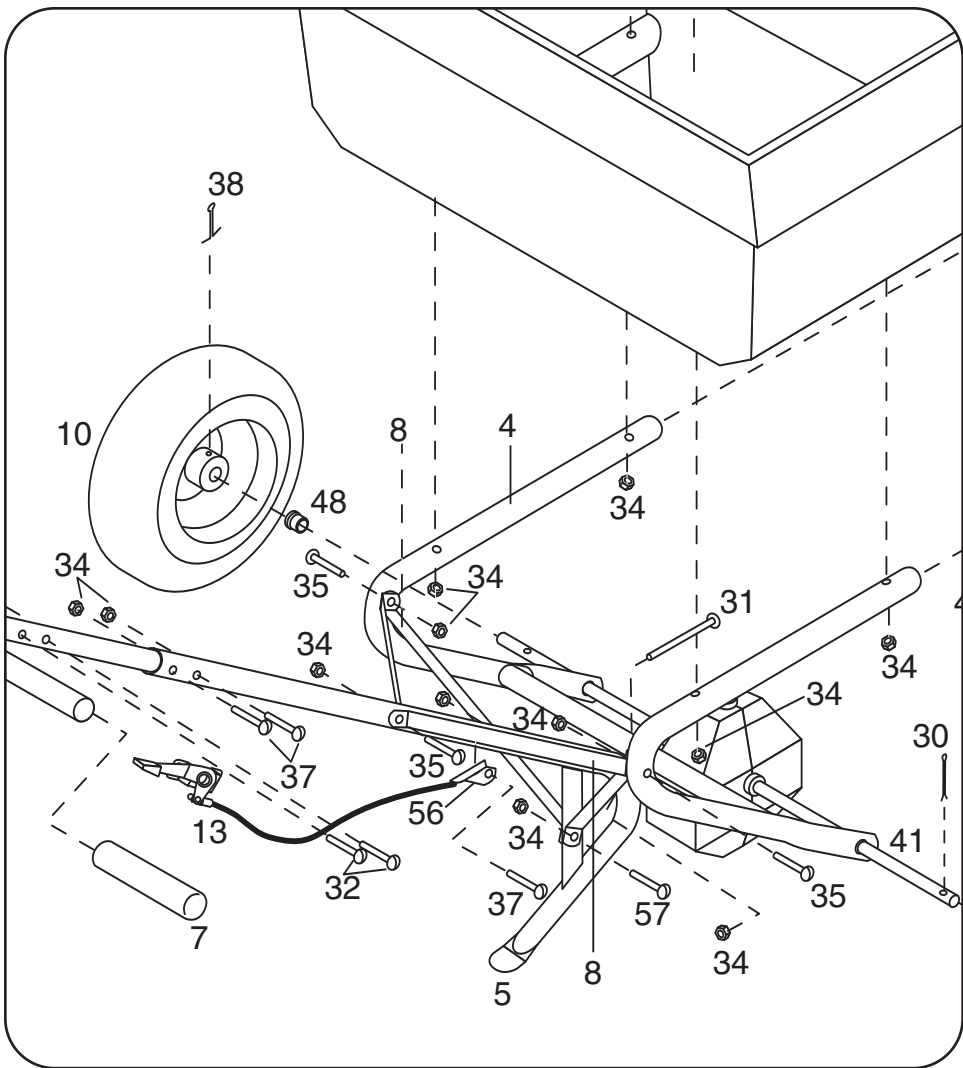

& Frame Assembly

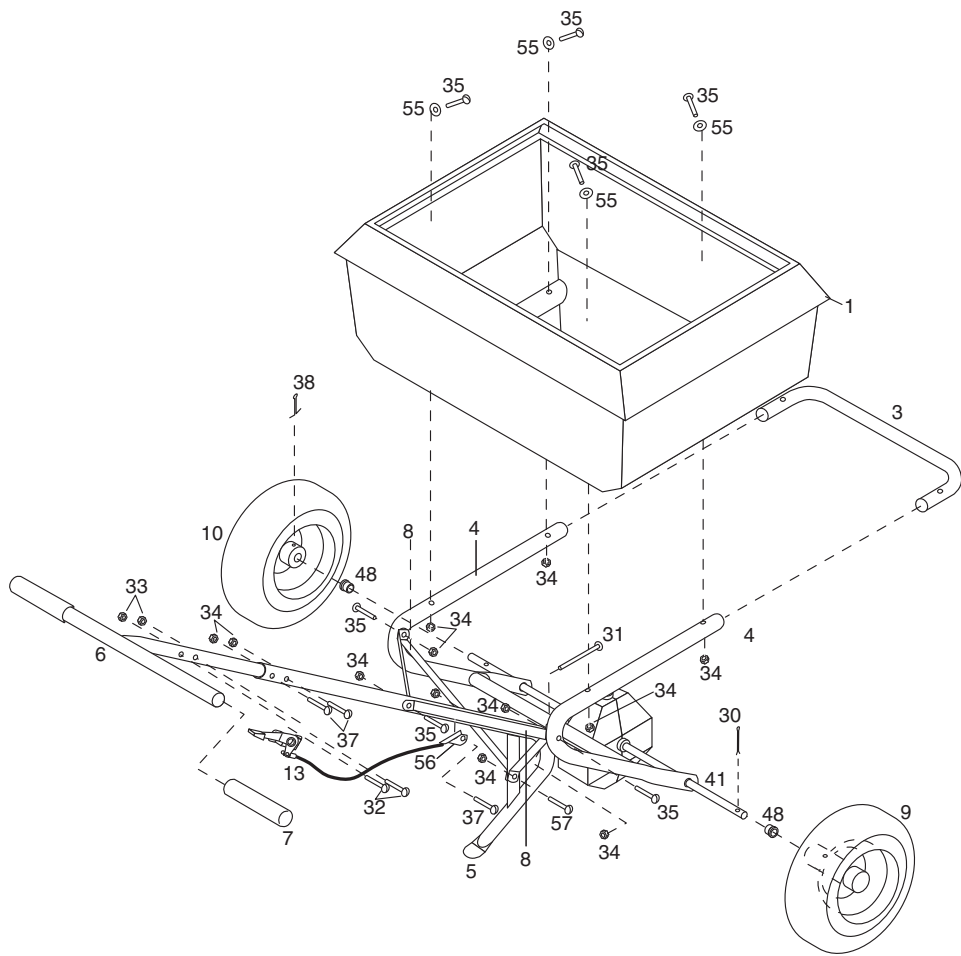

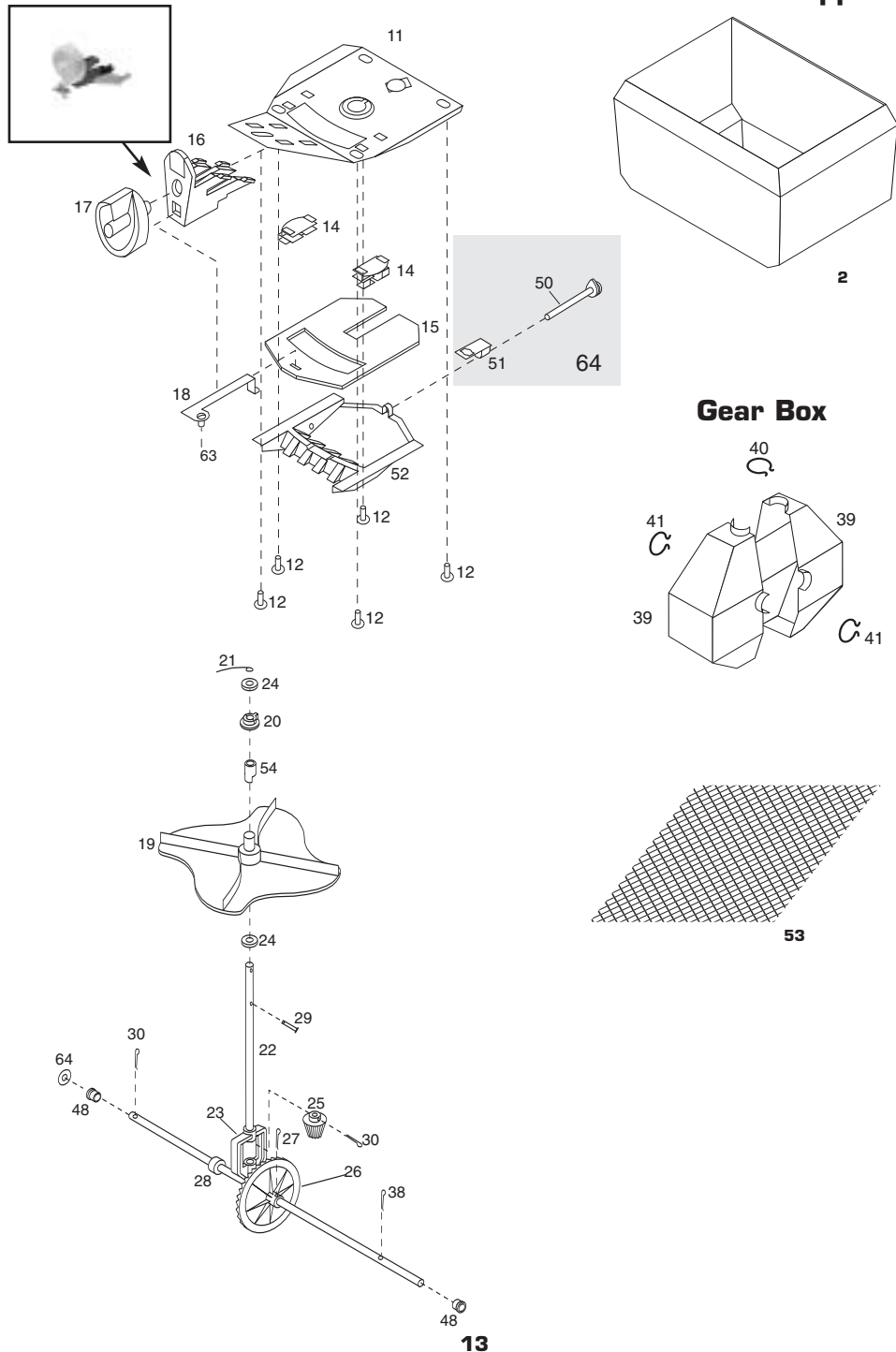

Stainless Hopper

Gear Box

Item #	Part #	Quantity	Description
1	05-94-0054-0	1	Hopper/Black
2	05-91-1100	1	Hopper/Stainless
3	05-81-1030	1	Hand Hold/Bump Bar/Painted
3	05-97-3030	1	Hand Hold/Bump Bar/Stainless
4	05-81-1020	1	Frame/Painted
4	05-97-3020	1	Frame/Stainless
5	05-94-1120	1	Ground Prop./Painted
5	05-98-3020	1	Ground Prop./Stainless
6	05-94-1010	1	T-Handle/Painted
6	05-98-3010	1	T-Handle/Stainless
7	05-94-0022	2	Handle Grip
8	05-81-1040	4	Brace for Ground Prop./Tow Bar/Painted
8	05-97-3040	4	Brace for Ground Prop./Tow Bar/Stainless
9	05-95-0017	1	Idle Wheel
10	05-95-0016	1	Drive Wheel
11	05-71-2205	1	Hopper Bottom Plate/Plastic Hopper
12	99-10-0205	5	1/4 - 20 x 1/2" Bolt/Hopper Bottom Plate
13	05-98-0018-1	1	On/Off Control Lever/Walk Behind
14	05-94-0042	2	Guide for Rate Gate/Diffuser
15	05-94-0068	1	Rate Gate
16	05-94-0069	1	Dial Mount
17	SS-94-0006	1	Dial
18	05-24-1101	1	Rate Gate Linkage
19	SS-94-0012-1	1	Spinner
20	SS-94-0007	1	Hopper Bottom Bearing
21	SS-96-0003	1	Agitator Wire
22	05-97-0021	1	Spinner Shaft 70 Series
22	05-97-0016	1	Spinner Shaft 90 Series
23	05-94-0035	1	Gear Support
24	SS-92-0002	2	Felt Washer
25	05-94-0034	1	Pinion Gear
26	05-94-0033	1	Bevel Gear
27	05-90-0014	1	Cotter Pin/Bevel Gear 3/16" x 3/4"
28	05-90-0012-R	1	Collar 5/8" Bore, 1 1/8" OD, 1/2" wide SS 5/16" - 18 Set Screw
29	SS-90-0002	1	Roll Pin/Spinner 1/8" x 7/8"
30	99-50-1081	2	Cotter Pin/Pinion/Gear 1/8" x 1"/Idle Wheel
31	05-90-0017	1	1/4 - 20 x 2 3/4" Bolt/Ground Prop. To Frame
32	05-90-0015	2	10 - 24 x 1 3/8" Bolt/Levers
33	05-91-0008	2	10 - 24 Lock Nut/Levers
34	SS-91-0004	11	1/4 - 20 Lock Nut
35	05-90-0016	8	1/4 - 20 x 1 3/4" Bolt/Hopper/Braces
36	05-93-1065	1	Axle
37	SS-90-0012	3	1/4 - 20 x 1 1/2" Bolt/T-Handle to Ground Prop.
38	05-90-0029	1	Cotter Pin/Drive Wheel 3/16" x 1 1/2"
39	05-94-0036	2	Gear Box Cover
40	05-98-0094	1	Gearbox Retainer Clip SS - Small
41	05-98-0095	2	Gearbox Retainer Clip SS - Large
42	99-50-1042	1	Hairpin Cotter #8
43	SS-90-0006	1	Clevis Pin/ 1/2" x 1 27/64"
44	05-81-1013	2	Hitch Plates/Painted
44	05-97-3013	2	Hitch Plates/Stainless
45	05-81-1110	1	Tow Bar/Painted
45	05-97-3210	1	Tow Bar/Stainless
46	05-98-0017-1	1	On/Off Control Lever/Tow Behind
47	05-94-0021	1	End Cap/Tow Bar
48	05-94-0028	2	Axle Bushings
50	05-94-0045	1	Accuway Adjustment Screw
51	05-94-0046	1	Accuway Adjustment Nut Bracket
52	05-94-0043	1	Diffuser
53	SS-96-0002	1	Screen
54	05-94-0049	1	Spinner Cam Extension
55	05-94-0064	4	Nylon Washer/Plastic Hopper Only
56	05-24-1105	1	Cable Clamp Tow Behind
56	05-81-1105	1	Cable Clamp Walk Behind
57	05-90-0047	1	1/4 - 20 x 1" Bolt
58	05-74-2350	1	Parts Bag for Push Spreader/Painted
59	05-73-2350	1	Parts Bag for Pull Spreader/Painted
60	05-78-2350	1	Parts Bag for Push Spreader/Stainless
61	05-79-2350	1	Parts Bag for Pull Spreader/Stainless
62	05-99-0078	1	Manual
63	05-90-0044	1	Cable Fastener
64	05-92-0004	1	5/8" Finishing Washer/Stainless

SPEED - ACCURACY - FREEDOM FROM STRIPES AND STREAKS are yours - when you use this Spreader.

The spread width ranges from 4 ft. to 12 ft. wide, depending on the volume/density, particle size of the material and the rate of travel.

The spread thins or feathers at the outer edges, eliminating sharp, "Edge of spread" lines which cause stripes and streaks. Extra coverage can be given under trees and other heavy feeding areas without showing "edge of spread" lines.

Gaps and double overlaps are less likely. Small errors in travel are forgiven and do not show.

WARNING: When spreading products containing herbicides, exercise extreme caution with respect to careless spreading and to wind-drift.

CONTACT OF SOME PRODUCTS ON SOME PLANTS CAN BE FATAL.

If a dial setting is not found, use the size and weight comparison table found on the back page.

Determine a dial setting on the low side. If the setting proves to be too low, cover the area more than one time. A higher setting can be used when a proven dial setting is established.

REMEMBER - Published dial settings can be approximate only. The operation of the spreader, the condition of the material (damp or dry or over-pulverized) and weather conditions, are all contributing factors.

For these reasons, it's often a good idea to spread the area 2 times - at one-half rate - in cross directions (SEE INFORMATION ON ONE-HALF RATE DIAL SETTINGS ON REFERENCE CHART ON THE BACK PAGE. SPREADING AT ONE-HALF RATE DIAL SETTINGS IS HIGHLY RECOMMENDED UNDER DAMP & HUMID CONDITIONS.

BECOME FAMILIAR WITH THE OPERATION OF THE SPREADER BEFORE YOU PUT MATERIAL IN THE HOPPER.

Practice walking with the spreader, opening and closing the rate gate at the appropriate times.

Travel at a constant speed and operate the spreader lever position.

Remember: Open the rate gate **after the spreader is in motion** at operating speed (about 3 mph., or at a brisk walking pace).

Close the rate gate while spreader is **still at operational speed.**

Rotary Agitator

Use the rotary agitator only if needed. Free-flowing, lump-free materials will not require the agitator. The rotary agitator is easily installed or removed. Note the clockwise rotation & sweep. Place felt washer around spinner shaft before inserting agitator. - See page 14.

OIL BEARINGS AND ALL MOVING PARTS

Make certain the spreader is running freely!

Now You are Ready to Put Material in the Hopper

- Make certain the *rate gate is in closed position.*
- As insurance against spill damage and spill loss, put material in the hopper with the spreader on a walk, driveway, paper, plastic, etc.
- The spreader will be easier to use if you only half-fill the hopper. Later on you can fill the hopper if you so choose.
- Or for added capacity, the inverted bag in the hopper can serve as a capacity extension. Also, an extension hopper, complete with filtering and pulverizing screen, is available from the manufacturer.

Now You are Ready to Spread

- Spread header strips at the ends of the area **OPPOSITE** the direction of spreading. This will provide a "turn-around" area, an area to realign the spreader for the return spread.
- Example is for 6 ft. wide spread: Make the first spreading pass at one-half the spread width from the edge of the spreading area or in this case approximately 3 feet or one big step.
- Additional spreading passes will be at the full spread width or approximately 6 feet apart.
- **TAKE A SIGHTING AT THE FAR END.** Keep your eye on the sighting as you spread. You will not need to wonder where you are or where you have been. Continue until spreading is completed.
- Left over fertilizer can be spread under trees and other high feeding areas without showing "edge of spread" lines.

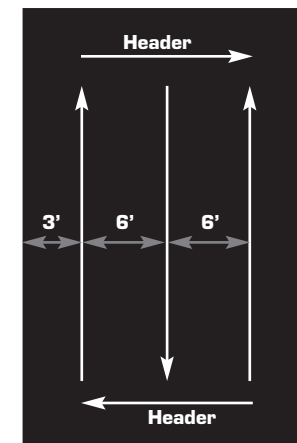

NOTE: With the rotary agitator installed, the rate gate closed (not spreading) and with material in the hopper, the spreader will push harder than normal. (This is because the agitator is stirring the material and it has no place to go.)

RECOMMENDATION: When not spreading and the spreader is being pushed some distance, tip the spreader so only the idle wheel is on the ground.

Cleaning the Spreader is Part of the Spreading Job.

IMMEDIATELY AFTER USE - CLEAN AND OIL THE SPREADER

- **Method #1** - Wipe spreader thoroughly with an oily cloth. Oil all bearings and bearing areas.
 - **Method #2** - Wash, rinse, and dry the spreader. Note: Drying takes time. (Moisture trapped in bearing areas is slow to go.) Immediately after drying - oil all bearings and moving parts. Make certain all operations are thorough.
- Note: Good "Dry Cleaning" is preferable to poor "Wet Cleaning".
- It is virtually impossible to have rust and corrosion on a clean, dry, oiled surface.
 - Again - just before using - oil all bearings and moving parts.
 - In storage, ideally the spreader should be hung by the handle. In any case, do not pile weight on the spreader, as excess weight over a period of time can distort the tires.

"Accuway" Use Instructions.

BALANCING THE SPREAD - A COMPLICATED PROBLEM WITH A SIMPLE SOLUTION

HERE'S THE PROBLEM - IT'S THE VARIABLES

It's the **VARIABLES**. Each variable has it's own spread pattern characteristics.

It's the **VARIABLES**. They're transposed and mirrored in the Spread pattern.

TRAVEL SPEED, HUMIDITY AND CONDITION OF PRODUCT ARE
MAJOR FACTORS IN **BALANCING THE SPREAD**

"To Every Action There Is Always An Opposed and Equal Reaction"
(Newton's law of motion - Sir Isaac Newton, 1642-1727.)

Accuway - What It Does



Accuway Spread Pattern Equalizer Balances the spread pattern - Bulls Eye - Dead to the Center of the Spreader. All products. All spreading conditions. Skewing is eliminated. Does not change the spread width.

CAUTION: Never, never, never use the Accuway to split the product flow from the hopper to the spreading spinner.

VARIABLES in product, weather, spreading equipment, spreader operator, etc., and combinations of **variable** elements produce **VARIABLES** in the spread pattern.

- **VARIABLES** include product size, weight, shape, surface finish, hygroscopic or non hygroscopic composition, condition of product (exposure to humidity, temperature, etc.)
- **VARIABLES** include spreading rate (light, medium, heavy).
- **VARIABLES** include size, shape, design of spreading spinner.
- **VARIABLES** include product dispensing on spreading spinner.
- **VARIABLES** include condition of the spreader end the spreading spinner (product build up on the casting vanes, etc.)
- **VARIABLES** include operator habits, fast or slow walking, tilting spreader forward or backward or operating spreader in a level attitude.

Accuway - How It Works

A turn of the spread pattern shifter dial factors the variables. Shifts the product placement on the spreading spinner. This in turn balances the spread pattern heavier to right or heavier to left as required. Adjustment is very sensitive. (Note the very fine threads on the Equalizer adjustment stem.)

Viewed from the operators position
To spread heavier left - move the ramp out.
To spread heavier right - move the ramp in.

The Accuway has two ramps. A front side and a back side ramp.

The front side ramp ② is used to shift the spread pattern to the right.

The back side ramp ① is used to shift the spread pattern to the left.

NEVER, NEVER, NEVER USE ACCUWAY FRONT AND REAR RAMPS TO SPLIT THE PRODUCT FLOW. Use only the front side or the back side. With proper adjustment you should be able to achieve a balanced spread pattern.

First - set the spread rate dial ③.

Now you are ready to balance the spread pattern.

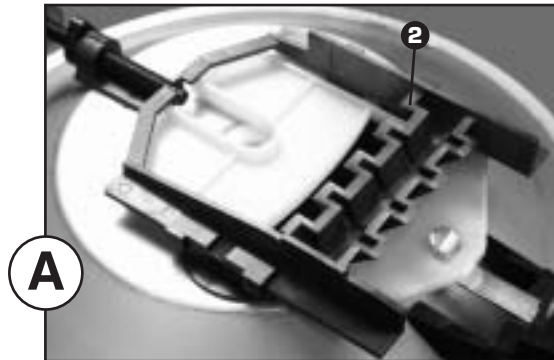

Note the relationship of the rate gate opening to the front side of the ramp.



Note the relationship of the rate gate opening to the back side of the ramp.

Dial settings are approximate only. Spreading at one half rate in cross directions is usually recommended.

Manufacturer and Product	Manufacturer's Bag Rate		Micro-Dial Settings		Spread Width (In feet based on brisk walking)
	Lbs. per 1000 Sq. Ft.	Sq. Ft. Coverage	Full Rate Once over	Half rate Twice over	
Bent Grass or Red Top	0.5#	1,000	1.25		4
	1#	1,000	2.0		4
	2#	1,000	2.5		4
Park, Merion, Delta, or Kentucky Bluegrass	0.5#	1,000	2.5		4
	1#	1,000	3.0		4
	2#	1,000	3.5		4
Hulled Bermuda	2#	1,000	2.75	2.25	6
	3#	1,000	3.0	2.5	6
	4#	1,000	3.25	2.75	6
Mixtures including coarse seeds	2#	1,000	6.0		6
	4#	1,000	7.0		6
	6#	1,000	7.0		6
Rye Grasses or Tall Fescue	2#	1,000	6.0		6
	4#	1,000	7.0		6
	6#	1,000	7.75		6
Dichondra	4 oz.	1,000	1.9		8
	8 oz.	1,000	2.1		8
	12 oz.	1,000	2.5		8
Pensacola Bahia	4#	1,000	4.5	3.75	7
	5#	1,000	4.75	4.0	7
	6#	1,000	5.0	4.25	7

Granule Size - Dial Setting Guide

Dial settings are approximate only.

Product	Lbs. per 1000 Sq. Ft.	Full Rate	Half Rate
Fine Pellets	1	3.6	3.1
	2	4.0	3.5
	3	4.2	3.7
Mixed Fine Pellets	2	3.7	3.2
	4	4.7	4.1
	6	5.2	4.5
Small Pellets	2	3	2.9
	4	4.2	3.7
	6	4.5	4
Nitrogen Pellets Med.	1	3.5	3
	2	4.2	3.7
	3	4.7	4
Med. Pellets & Granules	2	3.5	3
	4	4.2	3.8
	6	5.2	4.5
Med. Pellets	2	3.5	3
	4	4.2	3.8
	6	5.2	4.5
Large Heavy Pellets	2	3.8	3.3
	4	4.9	4.1
	6	5.9	4.9

Broadcast Spreading



Broadcast spreading is as old as early man. In the early days of agriculture, field seeding was accomplished with hand cast broadcasting. The hand cast method of seeding was a limited factor in growing field crops that were hand seeded.

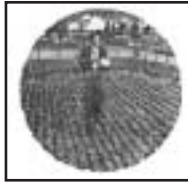

Mechanized casting came into being in 1868 when Samuel Speicher invented the Hand Crank "Cyclone" Seeder. The seed sower was a breakthrough in field seeding. It was hailed as a major advancement in agricultural implements.



Paul Speicher put the hand crank seeder on wheels in 1955. This development ushered in a new era in spreading and spreading products. New products and product forms adapted to broadcast spreading were developed.



In 1988 a new dimension was added to broadcast spreading - SPREAD PATTERN CONTROL - a dead center spread pattern equalizer. Spyker's Accuway® spread pattern equalizer solves a complicated problem with a fundamental patented solution.

Did You Know?

THERE'S MORE TO A SPREADER THAN MEETS THE EYE — LOTS MORE

Spreadability - Dial-a-matic regulator ensures exact spread rate. Accuway® Spread Pattern Equalizer assures exact placement of the spread pattern - Bull's Eye - dead to the center of the spreader. All products - All spreading conditions. Skewing is eliminated.

Durability - 70 & 90 Series spreaders will survive use and abuse. Welded steel construction is double braced, finished in baked on epoxy enamel. Generous use of highest quality stainless steel. Guaranteed metal gears.

Reliability - You can count on.

Accuway® spread control system is so innovative, it's patented. Is so successful it's used on all Spyker 70 & 90 Series spreaders. Is so simple. A complicated problem is solved with a fundamental solution. (Newton's law of motion: To every action there is always an opposed and equal reaction.)

Serviceability - 24 hour replacement parts service available direct from the factory. 70 & 90 Series spreaders shipped set up except hand hold/bump bar and push handle or tractor pull bar.

1 YEAR LIMITED WARRANTY

This is warranted to the original purchaser only, other than used commercially, against defects in materials and workmanship, for a period of one year from the date of purchase.

*For Spyker Spreaders LLC, products employing metal gear systems, pinion and bevel, these metal gears, only, not inclusive of any other parts or materials, are warranted for the life of the spreader, not to be used for replacement or repair past original purchase.

Spyker Spreaders LLC will not be liable for any loss, damage or expense including, but not limited to, consequential or incidental damages, arising from the operation, condition or use of the item. The sole and exclusive remedy against Spyker Spreaders LLC being the replacement of the defective parts. This warranty gives you specific legal rights, and you may also have other rights which vary from state to state.

THIS EXPRESS WARRANTY, WHICH IS APPLICABLE ONLY TO THE ORIGINAL PURCHASE, IS IN LIEU OF AND EXCLUDES ALL OTHER WARRANTIES, WHETHER EXPRESSED OR IMPLIED BY OPERATION OF LAW OR OTHERWISE, INCLUDING ANY WARRANTY OF MERCHANTABILITY OR FITNESS FOR PARTICULAR PURPOSE.

SPYKER SPREADERS LLC
P.O. Box 7 • Urbana, IN 46990 USA

