

Clayliter (open) DB-0902CU

Uplighting
Spot Lighting
Fountain/Statue Lighting
Highlighting
Sign Lighting
Wall Lighting
Backlighting
Reflective Lighting
Architectural Lighting
Mirror Lighting



Nightscaping®
1705 E. Colton Avenue
Redlands, California 92374
Tel: (909) 794-2121
Fax: (909) 794-7292
Help Line: (800) 544-4840
Email: wlocklin@nightscaping.com
<http://www.nightscaping.com>

Solve fixture visibility problems with the open, copper Clayliter. Consisting of a cylinder closed at one end by a tempered glass lens with available honeycomb louvered side shielding, and an integrated spike at the opposite end, this fixture allows for a fast and easy push-in installation.

Standard Lamp: DB-0902CU -LO2036 (Standard)

Material: **Body:** Copper

Finish: DB-0902 CU (Standard) Copper
DB-0902 CU-V Copper-Verde
DB-0902 CU-1, -2, -3, -4, -7, -8, -9, -AV, -VP, -W
(Optional w/surcharge)

Lens: Clear Pyrex Lens (Standard) - sealed with silicone

Socket: Ceramic G6.35 Bi-Pin

Mounting: Direct Burial (Standard)

Nightscaping[®] The Safe System

Claylter (open)

DB-0902CU



Nightscaping™ The Safe System

Alternative Lamps:	DB-0902CU	-LO1024*, -LO2006, -LO2012, -LO3512, -LO3520, -LO3540, -LO4208, -LO5012, -LO5024, -LO5038, -LO5055, -LH5024*, -LH5036* (Optional)
	BB-0802CU	-LO1141, -LO1156, -LO67, -LO89 (SCB Lamp Option* = Surcharge)
	BB-0802CU	-LO93 (SCB Lamp Option)

Lens: DB-0802CU-LO2036 -A, -B, -G, -MB, -R, -S (Optional)

Options: -RT Removable Top

Options: See above indications

Accessories:

Lens:	NS-CU-C (Standard/Accessory)	Clear Lens
	NS-CU-A, -B, -G, -MB, -R, -S	Colored Lens
Light Shield: Used for extra light shielding	0602-S-CU	Copper
	0602-S-CU-V	Copper-Verde
	0602-S-CU-1, -2, -3, -4, -7, -8, -9, -AV, -VP, -W (Optional w/surcharge)	
Louvre:	LR-0202	Round 1/8" Black Louvre - Steel

Warranty: 10-Year 'Repair or Replace' Warranty.

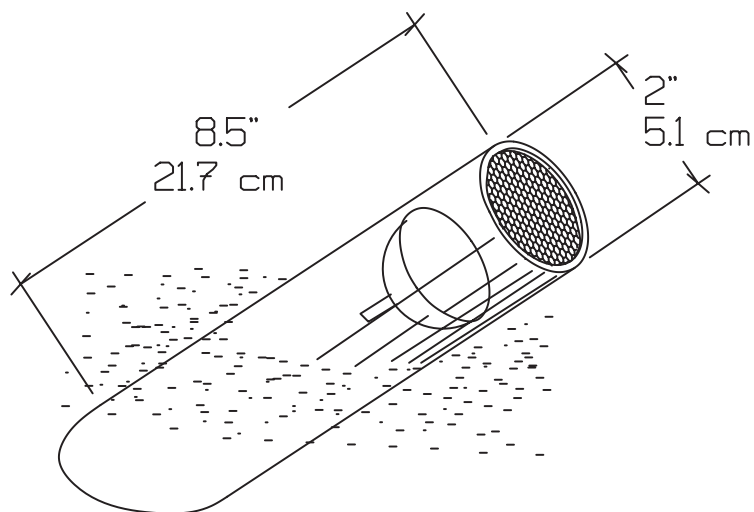

	LO 2036 (BAB) (20W)	42° x 42°
2ft	1'6"	131.3 FC
4ft	3'0"	32.8
6ft	4'7"	14.6
8ft	6'1"	8.2
10ft	7'8"	5.3
12ft	9'2"	3.7
14ft	10'9"	2.7
16ft	12'3"	2.1
18ft	13'9"	1.6
20ft	15'4"	1.3

STANDARD LAMP PHOTOMETRIC

DESIGN TIP*

This compact fixture is great for uplighting in small planters and pots.